

LEFT SIDE VIEW

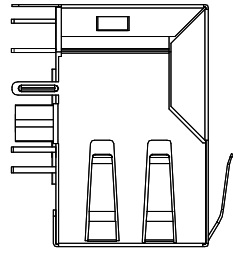

FRONT VIEW

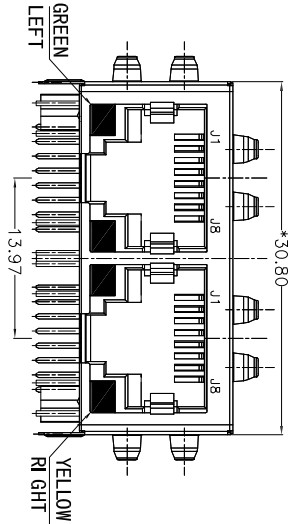

RIGHT SIDE VIEW

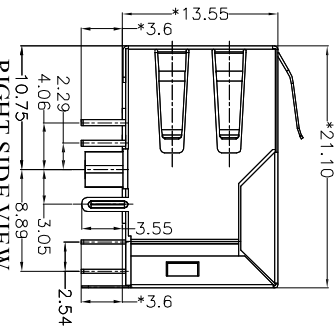

BACK VIEW

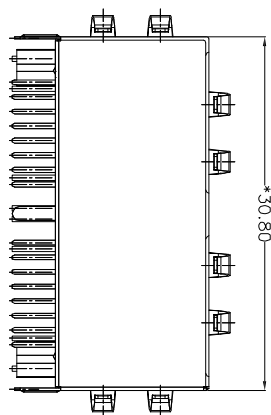

TOP VIEW

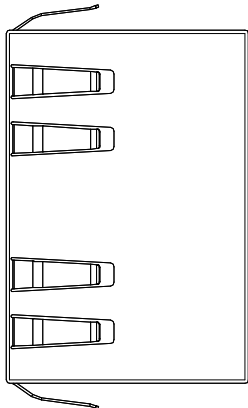

BOTTOM VIEW

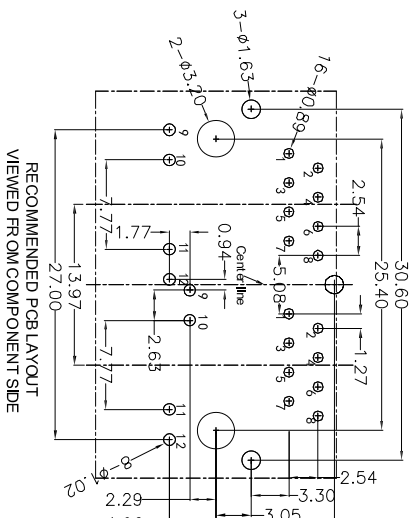
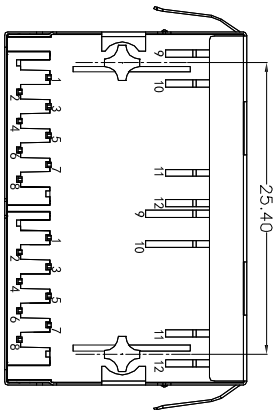

MATERIAL:

HOUSING: PBT,UL94V-0,BLACK
 TERMINALS BRACKET: PBT,UL94V-0,BLACK
 SHIELD: C2680,T=0.20MM,NICKEL PLATING ON ALL AREA.
 TERMINAL: PHOSPHOR BRONZE C5210,T=0.35MM,
 6U" GOLD PLATING ON CONTACT AREA

MECHANICAL:

DURABILITY: 750 CYCLES MIN
 MATING FORCE: 23N MAX.
 OPERATING TEMPERATURE: -40°C~+85°C.
 STORAGE TEMPERATURE: -40°C~+85°C.
 ALL CRITICAL DIMENSIONS WITH "**"

APPROVED:	DATE:
CHECKED:	DATE:
DRAWN:	DATE:
L. YAN	2020-12-11

Ckmtw 深圳市灿科盟实业有限公司 CHANKLEMENT INDUSTRYCO., LTD	
TITLE:	千兆网口 RJ45-10P/8C TAB-DOWN 1X2 H=21.1 带灯 带弹 带滤波器 十字脚
PART. NO.	R-RJ45R08P-D201
UNIT	mm
SCALE	Free
REV.	A0
FILE NO.	Ckmtw-RJ45-0268
REV.	KYD0

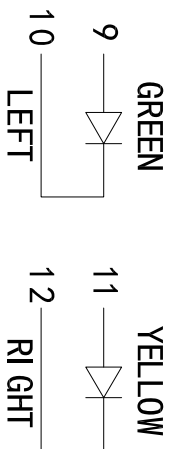
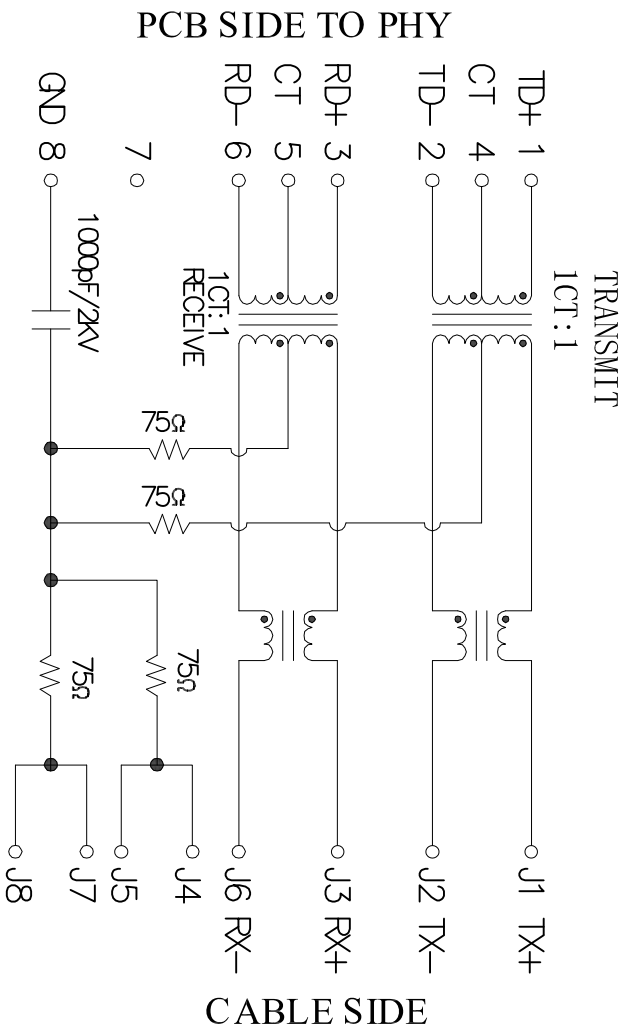

Electrical:

1. Turn ratio:1~2:J1~J2=1 CT:1 CT (±2%), 3~6:J3~J6=1 CT:1 CT (±2%).
2. OCL:350uH Min at 100KHz 100mV 8mA DC.
3. Insertion Loss: -1.0 dB Max 1~100MHZ.
4. Return loss: -20dB Min 1~10MHZ;
-16dB Min 10~30MHZ
-12dB Min 30~60MHZ
-10dB Min 60~80MHZ
5. Cross talk: -40dB Min 1~30MHZ;
-35dB Min 30~60MHZ;
-30dB Min 60~100MHZ;
6. CMR: -30dB Min 1~100MHZ;
7. Hi-Pot 1500V AC & 2250V DC
6S 1 mA PRI TO SEC

LED Specification

Standard LED Color	LED Wavelength	Forward(A)	Forward(V)
Green	568nm	20mA	1.85-2.45V
Yellow	585nm	20mA	1.7-2.2V

APPROVED:	DATE:	深圳市灿科盟实业有限公司 CHANKLEMENT INDUSTRYCO., LTD			
CHECKED:	DATE:	TITLE: 千兆网口 RJ45-10P/8C TAB-DOWN 1X2 H=21.1 带灯 带弹 带滤波器 十字脚			
DRAWN:	DATE:	PART. NO.	R-RJ45R08P-D201		
L. YAN	2020-12-11	UNIT	mm	SCALE	Free
		FILE NO.	Ckmtw-RJ45-0268	REV.	A0 KYD0

RECOMMENDED PANEL CUTOUT (REFERENCE ONLY) :

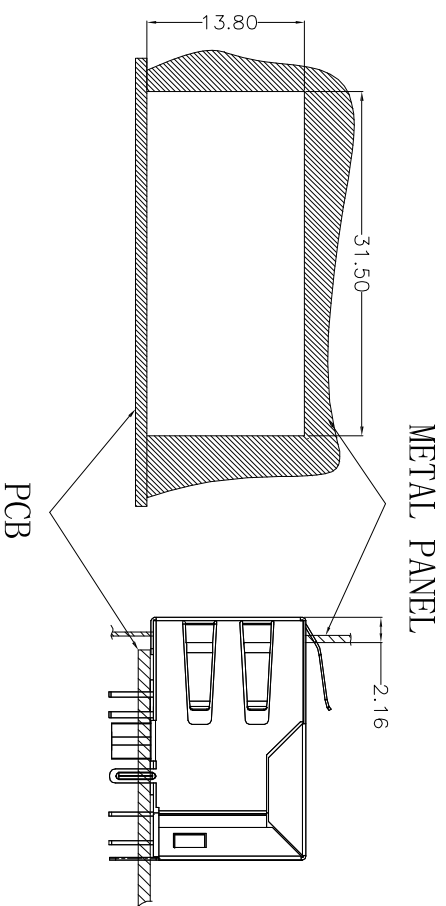

KEEP-OUT AREA (COMPONENT SIDE VIEW) :

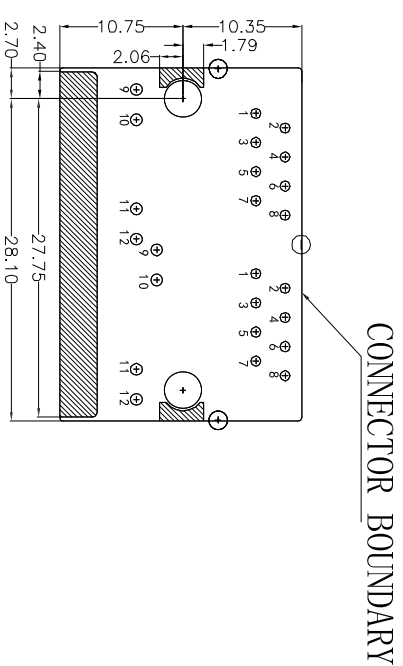

UNIT : MM / INCH
 TOLERANCES : ± 0.10 / 0.004
 REFERENCE ONLY

UNIT : MM / INCH
 TOLERANCES : 0.10 / 0.004

PLUG-IN SIDE

APPROVED:	DATE:	 深圳市灿科盟实业有限公司 CHANKLEMENT INDUSTRYCO., LTD			
CHECKED:	DATE:	TITLE: 百兆网口 RJ45-10P/8C TAB-DOWN 1X2 H=21.1 带灯 带弹 带滤波器 十字脚			
DRAWN:	DATE:	PART. NO.	R-RJ45R08P-D201		
L. YAN	2020-12-11	UNIT	mm	SCALE	Free
		FILE NO.	Ckmtw-RJ45-0268	REV.	A0 KYD0

PROFILE OF WAVE SOLDER

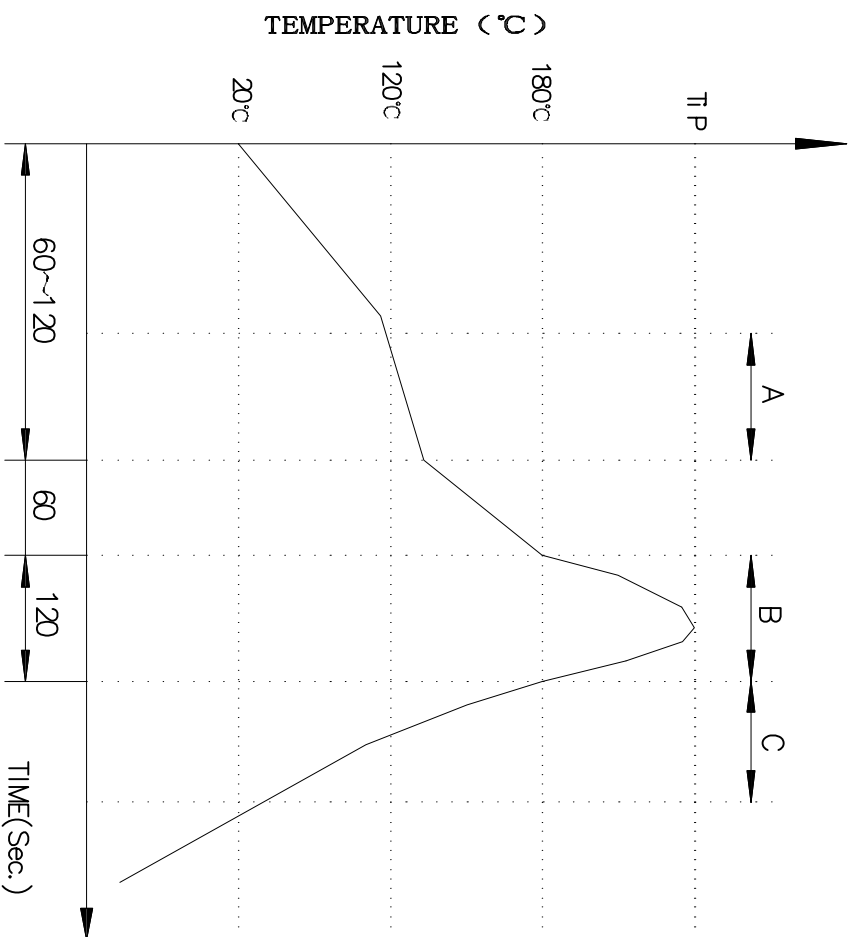

A. Preheating B. Soldering C. Gradual Cooling
 Tip temperature: $260 \pm 5^\circ\text{C}$.
 Tip temperature time: 5 Sec Max
 Tip melting point of Sn96.5/Ag3/Cu0.5: 217°C .

Remarks: after wave soldering, the plastic position columns of the product which under the PCB will be slightly melted, but it won't affect its function.

APPROVED:	DATE:	 深圳市灿科盟实业有限公司 CHANKLEMENT INDUSTRYCO., LTD			
CHECKED:	DATE:	TITLE: 百兆网口 RJ45-10P/8C TAB-DOWN 1X2 H=21.1 带灯 带弹 带滤波器 十字脚			
DRAWN:	DATE:	PART. NO.	UNIT	SCALE	REV.
L. YAN	2020-12-11	R-RJ45R08P-D201	mm	Free	A0 KYD0
		FILE NO.			
		Ckmtw-RJ45-0268			